

Subject: Application to Alter 126 York Street, a property designated under Part V of the *Ontario Heritage Act* and Located in the ByWard Market Heritage Conservation District

File Number: ACS2022-PIE-RHU-0018

Report to Built Heritage Sub-Committee on 10 May 2022

Planning Committee on 12 May 2022

and Council 25 May 2022

Submitted on April 20, 2022 by Court Curry, Manager, Right of Way, Heritage and Urban Design Services, Planning, Real Estate and Economic Development Department

Contact Person: Anne Fitzpatrick, Planner III, Heritage Planning Branch

613-580-2424,25651, Anne.Fitzpatrick@ottawa.ca

Ward: RIDEAU-VANIER (12)

Objet : Demande de modification du 126, rue York, une propriété désignée en vertu de la partie V de la *Loi sur le patrimoine de l'Ontario* et située dans le district de conservation du patrimoine du marché By

Dossier : ACS2022-PIE-RHU-0018

Rapport au Sous-comité du patrimoine bâti

le 10 mai 2022

Rapport au Comité de l'urbanisme le 12 mai 2022

et au Conseil le 25 mai 2022

Soumis le 20 avril 2022 par Court Curry, Gestionnaire, Services des emprises, du patrimoine et du design urbain, Direction générale de la planification, de l'immobilier et du développement économique

Personne ressource : Anne Fitzpatrick, Urbaniste III, Planification du Patrimoine

613-580-2424,25651, Anne.Fitzpatrick@ottawa.ca

Quartier: Rideau-Vanier (12)

REPORT RECOMMENDATIONS

That the Built Heritage Sub-Committee recommend that Planning Committee recommend that Council:

- 1. Approve the application to alter the building at 126 York Street, according to the plans dated February 16, 2022, conditional upon:**
 - a. The applicant providing a Letter of Credit in an amount to be determined through consultation between the applicant and City staff to ensure the protection, conservation and restoration of building prior to the issuance of a building or demolition permit;**
 - b. The implementation of the conservation measures identified in the Conservation Plan and as illustrated in the Conservation Elevations attached as Documents 13 and 14;**
 - c. The applicant submitting reports monitoring the condition of the historic structure from a professional engineer with heritage experience, to the satisfaction of Heritage Planning and Building Code Services;**
 - d. The applicant providing material samples for any new material to be used on the historic building to Heritage staff's satisfaction, prior to the issuance of a building permit.**
- 2. Delegate authority for minor design changes to the General Manager, Planning, Real Estate and Economic Development Department; and,**
- 3. Issue the heritage permit with a three-year expiry date from the date of issuance, unless otherwise extended by Council.**

RECOMMANDATIONS DU RAPPORT

Que le Sous-comité du patrimoine bâti recommande au Comité de l'urbanisme de faire les recommandations suivantes au Conseil :

- 1. Approuver la demande de modification du bâtiment situé au 126, rue York, conformément aux plans datés du 16 février 2022, sous réserve des conditions suivantes :**

- a. **Que le requérant fournisse une lettre de crédit d'un montant déterminé par suite d'une consultation entre le requérant et le personnel de la Ville, et permettant d'assurer la protection, la conservation et la restauration du bâtiment avant la délivrance d'un permis de construire ou de démolition;**
 - b. **La mise en place des mesures de conservation désignées dans le plan de conservation et illustrées dans les élévations de conservation, ci-joints en tant que documents 13 et 14;**
 - c. **Que le requérant soumette des rapports de surveillance de l'état de la structure historique rédigés par un ingénieur ayant de l'expérience en patrimoine, à la satisfaction de la Direction de la planification du patrimoine et des Services du Code du bâtiment;**
 - d. **Que le requérant fournisse des échantillons de tous nouveaux matériaux devant être utilisés sur le bâtiment historique, à la satisfaction du personnel chargé d'urbanisme, avant la délivrance d'un permis de construire.**
2. **De déléguer au directeur général de Planification, Immobilier et Développement économique le pouvoir d'apporter des changements mineurs aux plans reçus;**
 3. **D'approuver les demandes de permis en matière de patrimoine, valide pendant trois ans à compter de la date de délivrance, sauf si le permis est prolongé par le Conseil municipal.**

EXECUTIVE SUMMARY

The department recommends approval of the application to alter the building at 126 York Street, which is designated under Part V of the *Ontario Heritage Act* as part of the ByWard Market Heritage Conservation District. The proposed development is an adaptive reuse project which includes the restoration and alteration of the building at 126 York Street and the construction of a new 22 storey building that will be integrated with the historic building. This report has been prepared as applications for alteration under the *Ontario Heritage Act* require City Council approval. The proposal meets the Standards and Guidelines for the Conservation of Historic Places in Canada and the Council-approved guidelines for the ByWard Market Heritage Conservation District.

RÉSUMÉ

La direction générale recommande l'approbation de la demande de modification du bâtiment situé au 126, rue York, une propriété désignée en vertu de la partie V de la *Loi sur le patrimoine de l'Ontario* et située dans le district de conservation du patrimoine du marché By. L'aménagement proposé est un projet de réutilisation adaptée qui comprend la restauration et la modification du bâtiment situé au 126, rue York, et la construction d'un nouvel immeuble de 22 étages qui sera intégré à l'édifice historique. Le présent rapport a été élaboré parce que les demandes de modification faites en vertu de la *Loi sur le patrimoine de l'Ontario* requièrent une approbation du Conseil municipal. La proposition satisfait aux Normes et lignes directrices pour la conservation des lieux patrimoniaux au Canada ainsi qu'aux lignes directrices applicables au district de conservation du patrimoine du marché By et approuvées par le Conseil.

BACKGROUND

The property at 126 York Street, known as the Major Building, is located on south side of York Street, east of Dalhousie Street and west of Cumberland Street (See Location Map, Document 1). It is a five-storey building, constructed of reinforced concrete with brick and precast stone cladding. The building was designed as an industrial interpretation of the Beaux Arts style by C.P. Meredith, a well-known Ottawa architect. Meredith was appointed to the Ottawa Improvement Commission in 1910 and among his many works, designed the Carling Block on Sparks Street (See Photographs, Document 2).

The building was constructed in 1913, as a wholesale grocery warehouse for 'S.J. Major Wholesale Grocers and Wine Merchants'. Sylvanie Joseph Major, a Francophone entrepreneur, started the company in Orléans in 1879 and moved to Lowertown in 1899. Following his death in 1903, his wife Marie Corrine Lebel Major ran the business and established the York Street warehouse. She became a prominent businesswoman and played a major role in the merging of several grocery stores to form the National Grocers Ltd. in 1925. The building continued to be used as a warehouse until the early 1970s, when it was converted to office and retail uses. There is a three-storey addition on the east of the building that was constructed between 1928-1958, which is proposed to be demolished.

The subject property is a through lot with frontage on both York Street and George Street (126 York Street and 151 George Street). The northern portion of the property fronting on York Street, which contains the historic building, is located in the ByWard Market Heritage Conservation District (HCD), which was designated under Part V of the

Ontario Heritage Act by the City of Ottawa in 1991 (See HCD Map, Document 3). Originally established as part of the wider area of Lowertown, the ByWard Market dates to the 1820s and was the centre of Ottawa's commercial activities. As part of the HCD designation, each property was evaluated for its contribution to the cultural heritage value of the HCD and this building was identified as a Category 2 building, meaning it has significant cultural heritage value.

The proposed development is an adaptive reuse project which includes the restoration and alteration of the building at 126 York Street and the construction of a new 22-storey building that will be integrated with the historic building. The report has been prepared because applications for alteration under the *Ontario Heritage Act* require City Council approval after consultation with the Built Heritage Sub-Committee (See Demolition Plan, Site Plan, Elevations, Renderings in Documents 4, 5, 6 and 7).

The applicant has also submitted an application (ACS2022-PIE-PS-0051) for a Zoning By-law amendment under the Planning Act. The Zoning By-Law Amendment is anticipated to be considered at Planning Committee on June 9 and Council on June 22. In general, the City endeavors to have applications under the Ontario Heritage Act and Planning Act reviewed concurrently. However, in this instance, the heritage application is being considered in advance due to the 90-day timeline associated with applications under the Ontario Heritage Act which expires June 20, 2022 and to allow the applicant to move forward with the demolition of the additions, which do not have cultural heritage value, in a timely manner. The applicant also intends on applying for a grant under the Heritage Community Improvement Program to assist with conservation costs associated with the proposed works described in this report. A subsequent report will be submitted to the Built Heritage Sub-Committee to consider the grant application.

DISCUSSION

Project Description and Planning Context

The proposed development is an adaptive reuse project that will see the former warehouse building converted to a hotel and the construction of a 22-storey high-rise apartment building with rental units. A total of 214 hotel rooms and 280 residential rental units are proposed, with two levels of underground parking. The five-storey warehouse building will be conserved and rehabilitated. The proposed high-rise addition is set back 8.7 metres from the front façade of the existing heritage building. It features large expanses of glazing and light grey pre-cast concrete panels in smooth and textured finish. The new building steps back its height in landscaped terraces south from the historic building up to 22 storeys on the George Street frontage. The George Street

façade has a three-storey podium with dark brick and horizontal banding at the base of the building and matching pre-cast panels. There is a recessed one storey addition to the east of the historic building that features a restaurant.

A mid-block connection is proposed between York Street and George Street along the western edge of the site, to create a pedestrian link and provide vehicular access to the hotel. Underground hotel parking will be accessed via York Street along the eastern edge of the site, while underground residential parking will be accessed via George Street at the eastern portion of the site.

The proposed landscape alterations include the retention of the existing trees on the site. New trees are proposed to be planted along the northern portions of the east and west property lines and additional plantings are proposed along the sides of the building.

The application requires a Zoning By-law Amendment. The Minor Zoning By-law Amendment seeks to obtain relief from Maximum Building Height, Angular Plane Requirements, and Heritage Overlay. An earlier version of the design was reviewed by the Urban Design Review Panel on November 6, 2020, and June 4, 2021, and the design was subsequently revised to address the comments provided.

Alterations to the Historic Building

The overall conservation approach for the adaptive reuse project and development is *rehabilitation*, which according to Parks Canada Standards and Guidelines “involves the sensitive adaptation of an historic place or individual component for a continuing or compatible contemporary use, while protecting its heritage value.” This section will examine the restoration and alterations proposed to the historic building.

Restoration

A central component of this adaptive reuse project is the restoration of the historic building. Restoration work includes:

- The façade of the building and the first bay on the east and west façades will be retained and restored including the terracotta inserts and brick paneling.
- The brick masonry at the front and first bay side walls (red brick) will be conserved and restored through cleaning, repointing and repair.

- Stone masonry, including the limestone cladding on the first storey of the front façade and the stone foundation, will be cleaned, repointed and repaired as necessary.
- Metal cornices and trim will be preserved.
- The original wooden and glazed entrance door and sidelights and transom will be reconstructed based on documentary evidence.
- The opening on the ground floor of the front bay on the west side that had been converted to a door will be restored to a window opening.
- The front entrance, including stone entrance steps, door-surround with columns, stone lions and panel engraved with S.J. Major Ltd. will be restored and retained.
- Missing or poorly repaired tiles and bricks on the façade and first side bays will be replicated and replaced and the cladding repointed and cleaned.
- The cladding of the existing exposed concrete frame will also include repairs to damaged portions.

Masonry

The east, west and south façades of the building feature a concrete grid, infilled with brick, with and industrial style windows of varying shapes and sizes. The eastern façade has a one storey addition along the front and a three-storey addition towards the rear. Several alterations to the east and west façades have taken place to accommodate these additions and other changes such as new windows or entrances. The condition of the exterior masonry walls was assessed by Paterson Group Consulting Engineers who concluded that: “The exterior brick masonry of the infill walls was found to be in unsatisfactory condition. Deterioration, spalling and staining of exterior brick is evident in many locations and, in particular, at the junction with the concrete frame beams and columns and below windowsills” The report also notes that “At many locations, the reinforced concrete frames of the exterior walls was found to be in unsatisfactory condition as cracked and spalled.” The masonry report and a photo study of the masonry are attached as Documents 8 and 9.

The proposal is to remove and replace in-kind the infill walls on the side and rear façades with matching beige bricks, mortar and bond pattern. The concrete grid will be conserved and repaired where necessary and a fiberglass-reinforced concrete panel will

be applied. Where the three-storey addition on the eastern portion is to be removed, the masonry, including the concrete grid and brick work will be reconstructed.

Windows

The windows on the historic building are primarily metal, multi-paned, industrial style windows, some of which have central hopper openings. There is a mix of both original and replacement windows. The front façade has large, decorative windows, including four arched windows on the fifth storey. The ground floor has vertical rectangular windows, and the basement has horizontal rectangular windows. The windows on the side and rear facades are simpler, irregular in their pattern and size and have alterations. The proposed alteration is to replace all the windows in the historic building, reconfigure the fenestration pattern on the east and west façades and replace and missing windows in-kind. The proposed window details are included in Document 10.

The windows on the front façade and first bay of the side elevations, will be replaced in-kind with aluminum metal glazed units with true muntins and a fixed hopper. The concrete sills will be retained and restored where possible and replicated where necessary.

The reconfiguration of the windows is for both structural and practical reasons: the existing windows are embedded within the structure which makes repair difficult, and the current fenestration pattern is incompatible with the proposed new use in terms of interior layout and building code requirements. The windows will be aluminum metal glazed units with true muntins with concrete sills. The ground floor windows will be replaced on the east façade with one-over-one long rectangular aluminum metal glazed units based on historical imagery. The western façade will have similar style of windows on the ground floor but paired.

Where the three-storey addition on the eastern portion is to be removed, the windows will be reconstructed to match the rest of the facade. All lintels and sills on the York Street façade and first bay of the side façades will be retained and restored where necessary. The reconstructed bays on will have replicated concrete sills.

Recommendation 1 – Alter the existing property

The Parks Canada's Standards and the Guidelines for the ByWard Market HCD are the basis for the evaluation of this application.

Standards and Guidelines for the Conservation of Historic Places in Canada

City Council adopted Parks Canada's Standards and Guidelines for the Conservation of Historic Places in Canada ("Standards and Guidelines") in 2008. This document establishes a consistent set of conservation principles and guidelines for projects involving heritage resources. Heritage staff consider this document when evaluating applications under the *Ontario Heritage Act*. The following Standards are applicable to this proposal:

- Standard 1: Conserve the heritage value of the historic place.
- Standard 5: Find a use for a historic place that requires minimal change to its character-defining elements.
- Standard 10: Repair rather than replace character-defining elements.
- Standard 11: Conserve the heritage value and character-defining elements when creating any new additions to an historic place or any related new construction. Make the new work physically and visually compatible with, subordinate to and distinguishable from the historic place.

Conservation of Heritage Value

The cultural heritage significance of the Major Building is found in its design, historical and contextual value. It has design value as an excellent example of a Beaux Arts-influenced industrial building in Ottawa. It has historic value for its associations with well-known local architect C.P. Meredith and the Major family, a prominent Francophone entrepreneurial family in early 20th century Ottawa. It also has historical value as a purpose-built grocery warehouse within the historic commercial centre of the ByWard Market. The building has contextual value as a landmark along York Street and within the ByWard Market HCD.

The proposed alteration retains the cultural heritage value of the Major Building through the conservation of its heritage attributes. Through staff analysis and the Cultural Heritage Impact Statement, the heritage attributes identified for 126 York Street include:

- Five-storey massing
- Stone and brick cladding
- York Street façade with decorative parapet with pressed, curved metal cornice

- Industrial style metal windows
- The fenestration pattern of the front portion of the building
- Stone details including the string courses and ornamental tiles
- Stone entrance with columns, engraved building name and ornamental stone lions
- Exposed concrete grids on the sides of the building

As detailed in the description section above, these heritage attributes are conserved as part of the proposal. Original material is retained and restored wherever possible or is replaced in kind. The alterations to the east, west and rear facades, include replacement with in-kind material and the change in fenestration pattern is complementary to the original and maintains the industrial character of the building.

The proposal will remove later additions, including the three-storey addition to the east of the building and the exterior elevator enclosures on the south elevation that detract from the cultural heritage value and will restore the portions of the heritage building impacted by these additions.

The proposal conserves the cultural heritage value of the ByWard Market Heritage Conservation District through the restoration and adaptive reuse of a building with a significant historic connection to the area's historic market use. The five-storey massing of the historic building is retained in its entirety and remains legible, thereby maintaining the streetscape character on York Street. The step-back design of the new building transitions the height south towards George Street and outside of the HCD boundaries as intended by the HCD Study. The higher portions of the building will be visible within the HCD within the context of other existing and proposed high-rises for the area.

Construction of a high-rise building in the ByWard Market HCD can be challenging as it can create a conflict in scale. The ByWard Market HCD is characterized by its low scale particularly in the market core, to the west of this site. This proposal is successful because it has a use for the historic building that requires minimal intervention; it retains the historic building in its entirety as a focal point of the development; the height of the new building is set back from the front façade; the height transitions away from the historic building and away from the core of the HCD; and it uses compatible materials and articulation at the lower levels and then lighter materials on the upper storeys.

Use of a Place and Character-Defining Elements

The design for the proposed adaptive reuse ensures that minimal changes are required to the character defining elements of the historic building. The adaptive reuse retains and restores the existing building. The new hotel entrance has been located on the ground floor at the back of the historic building, an area which was previously altered to accommodate a loading zone. The location of this entrance allows for minimal changes to the historic front façade and specifically the front entrance. The character defining elements of the Major Building are maintained and restored as part of the proposal.

Compatible, Subordinate and Distinguishable

The new addition is compatible, distinct and subordinate to the historic building. Although significantly taller than the historic building, the proposed addition has been carefully designed to ensure that the historic building remains the prominent feature of the development. The new addition is set back 8.7 metres from the front façade, which allows the massing of the historic building to remain legible. The terraced step-backs successfully move the height away from the heritage building and results in a building that remains respectful of the scale and character of the heritage property. Although much taller than the existing building, the addition has been designed to not overwhelm the historic building.

In terms of compatibility, the first nine-storeys of the rear portion of the addition use materials that are sympathetic to the historic building including a dark brick, industrial style windows and a string course that extends the horizontal lines from the concrete grid. The addition is distinct from the heritage building as it is contemporary in design and materials. The upper storeys use textured and smooth, light grey pre-cast concrete panels and large areas of glazing, which is distinct from the darker masonry of the existing building. The two-storey stepped back terraces appear lighter when contrasted against the solid form of the heritage building. The one-storey addition proposed to be attached to the east façade, which will contain a restaurant, is compatible with the historic building as it is simple in design, setback from the front façade, uses compatible material with its brick.

ByWard Market HCD Guidelines

The ByWard Market Heritage Conservation District study was approved by Council in 1990. The Study contains guidelines to manage change in the heritage conservation district. The proposal is consistent with the applicable guidelines found within the ByWard Market Heritage Conservation District Plan related to architectural

conservation, rehabilitation and adaptive re-use and infill. A chart detailing an analysis of the HCD Guidelines can be found as Document 11.

The relevant Maintenance and Repair guidelines under Section 3.1 Conservation, have been followed. As noted in the sections above, the overall approach is to repair and restore the historical elements of the building or replacement damaged or missing elements in-kind. The building has been thoroughly documented, including a laser scan, and has been submitted to the City and will be shared with the City Archives.

As recommended in the Rehabilitation and Adaptive Re-use policies of Section 3.3 of the Plan, the proposed new use is being accommodated within the existing historic structure and the alterations respect the original design intentions of the building. As outlined in Section 3.5.1, the proposed infill respects the heritage character of both the area and the building. The most notable character defining elements of the building are retained and the addition is of its own time and is respectful of the scale and character of the heritage property.

Conditions

In order to ensure the conservation of the historic building a number of conditions are recommended:

a) Letter of Credit

Staff recommend that the owner be required to provide a Letter of Credit to the City in an amount equal to the estimated cost to protect the historic building. This Letter of Credit would be required prior to the issuance of any permits under the *Building Code Act* and would be held by the City until the conservation work on the historic building is completed. The amount of this security and the details of the agreement will be determined through negotiations between Heritage and Legal staff and the applicant.

b) Implementation of the Conservation Plan

Staff recommend that the conservation measures described in the Conservation Plan and illustrated on the Conservation Elevations be implemented as part of this project (Document 13 and Document 14). The Conservation Plan, together with the Conservation Elevations, provide direction on the restoration of conserved elements such as the stone masonry, the brick on the front portion of the building, and metal cornices and trim. It also provides conservation direction for elements to be altered, repaired or replaced in-kind such as the front door, windows and brick masonry. It

outlines a conservation process that requires recording, salvaging and monitoring of the development.

c) Structural Monitoring Reports

Staff recommend engineering reports monitoring the condition of the historic structure be submitted by a professional engineer with heritage experience. The frequency and duration of the reports will be determined in consultation with Heritage Planning and Building Code Services. This condition has been included to ensure that the building and its important attributes will be protected and conserved during the construction process.

d) Material Samples

Staff have included a condition of approval to provide final material samples for heritage staff's approval, prior to the issuance of the building permit. As some of the materials have not yet been finalized, this condition will ensure that the final chosen products will be consistent with the HCD.

Cultural Heritage Impact Statement

Section 4.6.1 of the existing City of Ottawa Official Plan and 4.5.2 (2) of the Council approved New Official Plan requires that a Cultural Heritage Impact Statement ("CHIS") be submitted where a proposed development has the potential to adversely affect the heritage resource. A Cultural Heritage Impact Statement (CHIS) was prepared for this proposal by Bray Heritage and is attached as Document 12. The CHIS concludes:

Rehabilitation of the existing five-storey building is the recommended intervention in the built heritage resource. The former warehouse is an important component of the ByWard Market Heritage Conservation District, and its conservation will support and enhance the heritage character of that part of Ottawa's downtown. Its adaptive reuse as a hotel, combined with rental housing, will reinforce the hospitality and rental residential character of the Market area.

Conservation and enhancement of the existing building and the York and George streetscapes will further the City's plans for local public realm improvements. Although the new addition is much larger than the existing warehouse and surface parking lot, the additional height of new construction will compare closely with the existing and anticipated high-rise development along George Street and will be set back from views taken from within the HCD, with the warehouse and stepped massing of the new addition providing a transition from York Street to

the part of the property located outside the HCD. Although the new addition overlaps the roof of the warehouse, the proposed development conserves the built heritage resource. Comments from the UDRP have been addressed with cladding elements that help link the warehouse with the new addition.

Heritage staff concur with the findings of the CHIS.

Conclusion

The Department recommends approval of the application to alter the building at 126 York Street. The proposal meets the applicable heritage guidelines in the “Standards and Guidelines” and the ByWard Market HCD Guidelines. The rehabilitation and adaptive reuse of the historic structure conserves and enhances the cultural heritage value of the historic Major Building and the ByWard Market HCD. The proposed conditions recommended in this report will help ensure that the proposed work will be undertaken in a manner that conserves the heritage value of the building.

Recommendation 2 – Minor Design Changes

Minor design changes to a building may emerge during the working drawing phase of the project and through the site plan process. As is common practice for heritage applications, this recommendation is included to delegate the authority to the General Manager, Planning, Real Estate and Economic Development to undertake these changes.

Recommendation 3 – Heritage Permit Expiry

The *Ontario Heritage Act* does not provide any timelines for the expiry of heritage permits. A three-year expiry date is recommended to ensure that this project is completed in a timely fashion.

Provincial Policy Statement

Staff have reviewed this proposal and have determined that it is consistent with the Provincial Policy Statement, 2020.

RURAL IMPLICATIONS

There are no rural implications associated with this report.

CONSULTATION

The plans were posted on the City's Development Application website on April 2, 2022.

Heritage Ottawa was notified of this application on April 5, 2022 and offered the opportunity to provide comments.

The Lowertown Community Association (CCA) was notified of the heritage permit application on April 5, 2022.

Neighbours within 30 metres of the property were notified of this application and offered an opportunity to comment at the Built Heritage Sub-Committee meeting.

Consultation for the Zoning By-law Amendment will be addressed in the associated staff report - ACS2022-PIE-PS-0051.

COMMENTS BY THE WARD COUNCILLOR

Councillor Fleury provided the following comments on the application:

“With a city rich in history as Ottawa is, we as communities are constantly faced with development applications to alter or demolish heritage buildings. From redevelopment, demolition by neglect or poor design integrations –it is generally up to the community and Heritage Ottawa to fight to retain its history.

It can be exhausting. But the fight is always worth every breath. That is why this proposal is a breath of fresh air.

It is not very often that we are presented with an application that mixes old and new so suitably.

When it comes to the design of integrating one of Ottawa's heritage landmarks with a new, purpose-built hotel and rental building this applicant worked hard to get it right with design, massing, and materials features. I am pleased that from the start, the plans included the retaining and repurposing the Major Building at 126 York Street. It is clear the architect has done a lot of work to connect the old and new, in a way that not only works, but respects the history as much as we do. Many of the times we see the “design by committee” – when requests are made to alter or add, beyond what is already proposed – to fix or ensure that the building is in keeping with Ottawa's city's skyline or its heritage attributes. That happens when owner/developer doesn't hire the right architect or when the development aspiration simply neglects the heritage character, which is the opposite in this case. The adaptive reuse of the former building, and the

stepped back 22-storey tower allows for the project to not overwhelm the street. And here we have a building that not only hit the mark the first time, but also, we have an active and engaged applicant who continues to work with the community to make it the best it can be.

More so, as the site includes access on George Street, adjacent to another redevelopment at 201 Rideau Street. Here the project includes the revitalization of Waller Mall. The formally closed mall will be upgraded and reopened for public access. This is a prime opportunity to create a cohesive connection between the two projects, to add vibrancy and a pedestrian-friendly atmosphere to this east-end portion of the Byward Market. I look forward to discussing further the pedestrian spaces and future crosswalk connection here with the applicant.

The proposal, which also will add rental units in addition to the hotel piece is another welcome feature – My hope is the units are diverse in sizes and bedroom counts, allowing for 2 or more bedrooms, to accommodate young families, or ageing seniors looking to downsize, but to stay in the heart of downtown is vital to supportive the vibrancy of the ByWard Market.

The proposed building does have important frontages on both George and York Street which are important to the connections along these prominent streets in the Byward district. Thanks to proper investment in design, I am pleased to see the attention to detail in the lighting around the building and the amenities that are proposed for tenants (outdoor terraces) This allows for open, safe, and welcoming spaces without creating dark areas or unwanted alcoves.

The welcoming design presented could make this building a landmark in Ottawa's core.

As we continue the conversation with this project through the site plan process, I look forward to seeing how this proposal shapes up for this property.”

LEGAL IMPLICATIONS

There are no legal implications associated with implementing the report recommendations.

RISK MANAGEMENT IMPLICATIONS

There are no risk management implications associated with this report.

FINANCIAL IMPLICATIONS

There are no direct financial implications.

ACCESSIBILITY IMPACTS

There are no accessibility implications associated with this report.

TERM OF COUNCIL PRIORITIES

This project addresses the following Term of Council Priorities:

- Thriving Communities: Promote safety, culture, social and physical well-being for our residents.

APPLICATION PROCESS TIMELINE STATUS

The statutory 90-day timeline for consideration of this application under the *Ontario Heritage Act* will expire on 2022-Jun-20

SUPPORTING DOCUMENTATION

Document 1 Location Map

Document 2 Current Condition

Document 3 HCD Map

Document 4 Demolition Plan

Document 5 Site Plan

Document 6 Elevations

Document 7 Renderings

Document 8 Paterson Group – Exterior Masonry Infill Wall Review

Document 9 Photo Study of Masonry Condition

Document 10 Window Details

Document 11 Byward Market HCD Evaluation Chart

Document 12 Cultural Heritage Impact Statement

Document 13 Conservation Plan



Document 14 Conservation Elevations

DISPOSITION

Office of the City Clerk, Council and Committee Services, to notify the property owner and the Ontario Heritage Trust, 10 Adelaide Street East, 3rd Floor, Toronto, Ontario, M5C 1J3) of Council's decision.

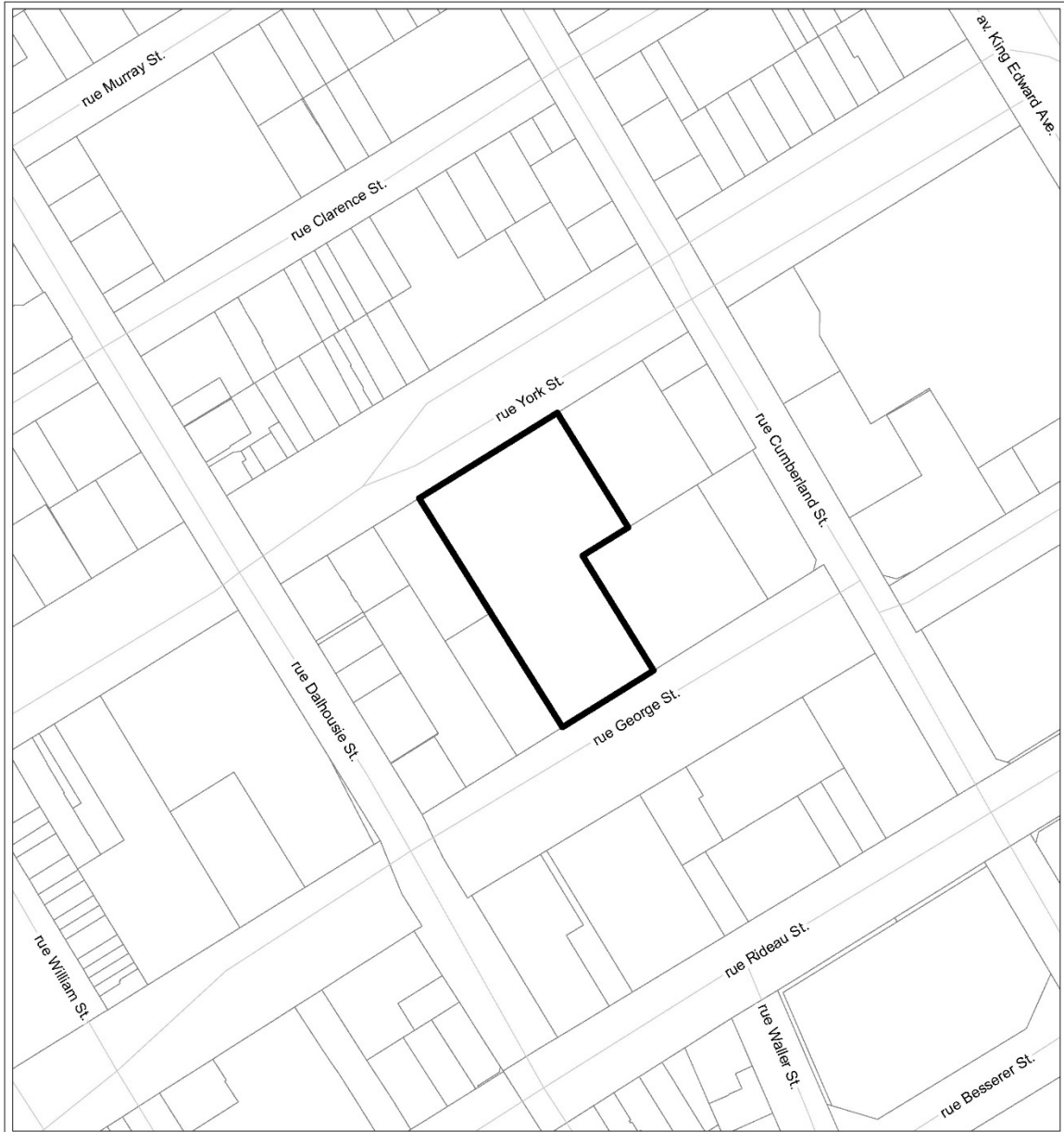
Document 1 – Location Map



		LOCATION MAP / PLAN DE LOCALISATION HERITAGE / PATRIMOINE	
D09-01-YOR126	22-0247-L	 126 rue York St.	 <small>NOT TO SCALE</small>
I:\CO\2022\Heritage\York_126			
<small>©Parcel data is owned by Teranet Enterprises Inc. and its suppliers All rights reserved. May not be produced without permission. THIS IS NOT A PLAN OF SURVEY</small>			
<small>©Les données de parcelles appartiennent à Terranet Entreprises Inc. et à ses fournisseurs. Tous droits réservés. Ne peut être reproduit sans autorisation. DÉCI N'EST PAS UN PLAN D'ARPENTAGE</small>		REVISION / RÉVISION - 2022 / 03 / 22	

Document 2 – Current Condition

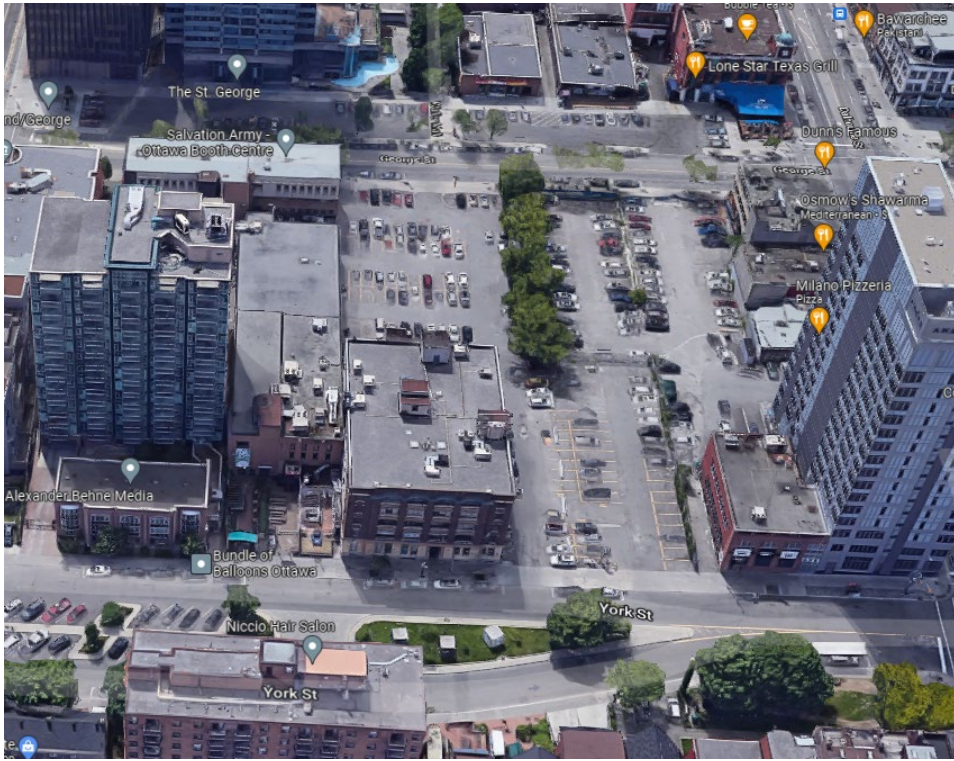





Document 10 – Window Detail

Relia 2022

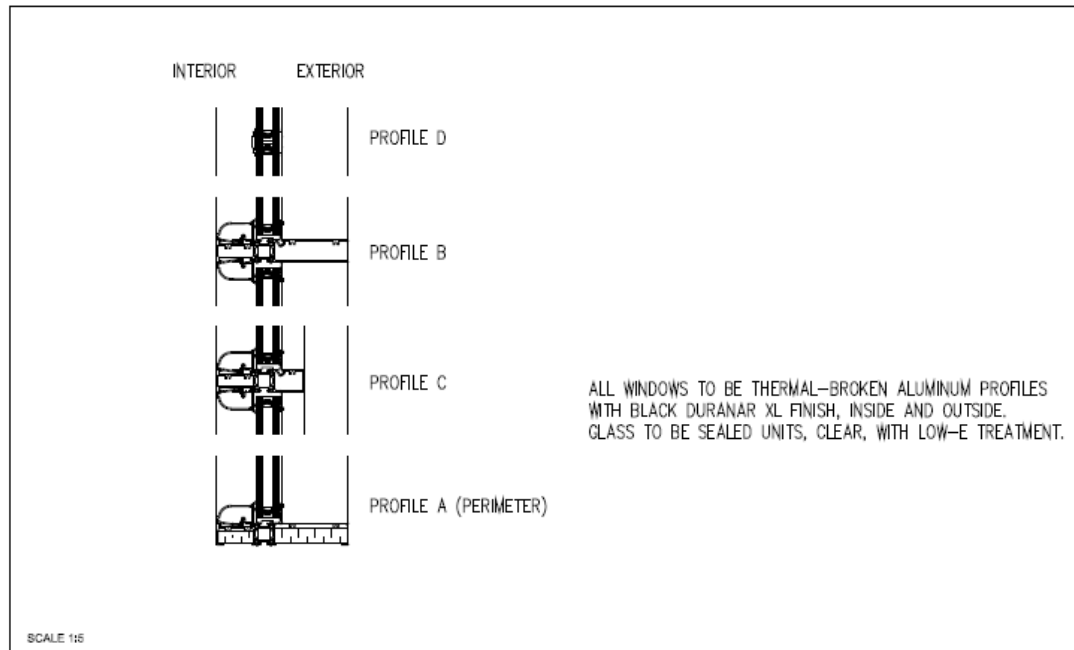
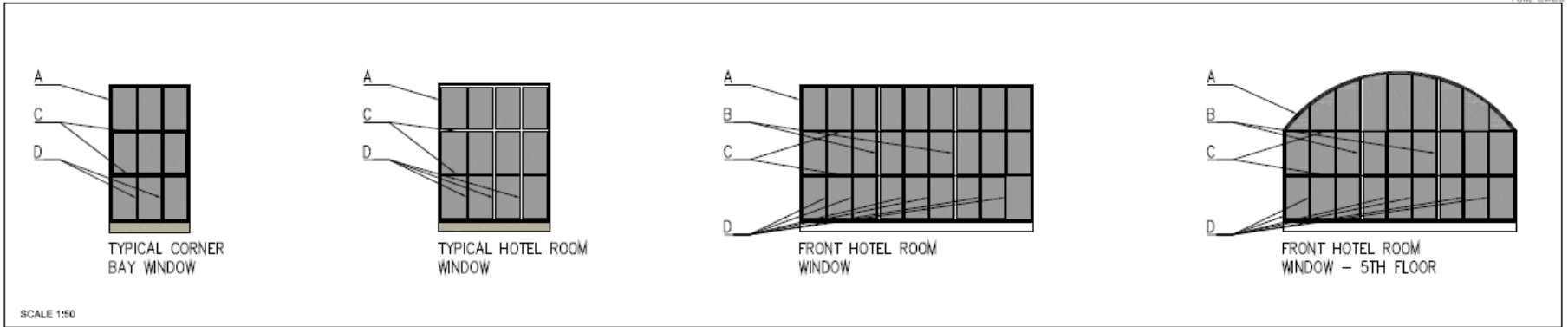

Document 11 – Byward Market HCD Evaluation Chart

Section of HCD Plan	Applicable Policy (#) and Guidelines (x)	Staff comment
<p>3.1. Conservation and</p> <p>3.2 Restoration</p>	<p>3.1 Comment: Maintenance and repair is the most important mechanism for preserving the character of individual heritage properties</p> <p>Applicable sections include Masonry Buildings; Pressed Metal Elements; Brick veneer; Windows; Doors</p>	<p>The overall approach is to repair and restore the historical elements of the building. Where replacement in necessary, as is the case with the windows and brick infill on the side facades, it will be replaced in-kind. Detailed conservation direction will be implemented through the Conservation Plan and Conservation Elevations attached as Documents 13 and 14.</p>
<p>3.3 Rehabilitation and Adaptive Re-use</p>	<ol style="list-style-type: none"> 1. As with restoration, good rehabilitation is based on good historical documentation. 2. If new or modified uses are proposed, it should first be determined whether these can be contained within the heritage property without undue damage to the layout or finishes. 3. Structural upgrading, if required, should respect the original design intentions and 	<p>The proposed rehabilitation uses historical documentation to inform the new development. The proposed new use is being accommodated within the existing historic structure. All upgrades respect the original design intentions of the building and interior and exterior layouts respected. The most notable character defining elements of the building are retained. The new</p>

	<p>reinforce these rather than working independently of them.</p> <ol style="list-style-type: none"> 4. New mechanical and electrical services and other environmental control systems including insulation should be introduced in ways which do not upset the existing equilibrium or create new possibilities for deterioration. 5. Architectural layout and finishes should be respected, both inside and outside a property. 6. Distinctive features and good examples of design and craftsmanship should be retained. The contribution of all periods to the history of the property should be respected. 7. New work should be of its own time, but subservient to the heritage character of the existing property. It should take its form and direction from the history of the property itself. 	<p>building is of its own time but takes direction from the existing building, especially on the ground floors.</p>
<p>3.4 Infill: Commercial and Mixed Use</p>	<ol style="list-style-type: none"> 1. Infill in commercial areas must respect the scale and character of existing heritage properties and streetscapes. 	<p>Because it is set back from the front façade of the building, the new tower maintains the scale and character of the existing property and York Street streetscapes. The</p>

	<p>2. The traditional pattern on commercial facades in the market area is grade level commercial or retail, with signage and cornice lines providing a visual separation from commercial or residential occupancies above. The different levels are also distinguished by larger window areas at grade and smaller windows, often with decorative surrounds, on the upper floors. Such patterns should be respected. The creation of split-level “ground floors” or new mezzanine levels should be discouraged.</p> <p>3. The horizontal scale of development is important. Traditional store widths of about thirty feet ensured continuous sidewalk activity. Enclosed malls or lobbies are inappropriate, where they create widely spaced entry and exit points.</p> <p>4. Mid-nineteenth century storefronts had substantial columns at regular intervals, with fairly confined window openings. By the late nineteenth century, cast iron columns and beams, and larger glass sizes, allowed more openness. Structural systems by the mid-twentieth century allowed continuous walls of</p>	<p>creation of an alternative hotel entrance on the south façade allows for the existing front entrance to be maintained. The setback and height is compatible with other properties in the area. There is no surface area parking being proposed. The distinctive features of the building including the metal cornices, entrance with decorative stonework, brick and stone cladding and the concrete grid on the side facades are conserved.</p>
--	--	---

	<p>glass. In designing new infill, the historic pattern of the buildings previously on the site and of adjacent properties should be considered and reflected in the new work.</p> <ol style="list-style-type: none">5. Building setbacks and heights should respect adjacent heritage properties and the streetscape. Road widening allowances should not be considered within the district.6. Carriageways and rear courtyards should be maintained where possible. Mid-block pedestrian links are one way of enhancing the commercial viability of these areas. In general, the pattern of high density development at the street edge should be respected.7. Parking in rear yards, with access through carriageways or side lanes, is the only surface parking that is appropriate in the district. Wide access ramps should not be used for any kind of parking as they disrupt the continuity of the street edge.8. Distinctive features and good examples of design and craftsmanship should be retained.	
--	--	--

	<p>The contribution of all periods to the history of the property should be respected.</p>	
<p>3.5 Infill: Residential</p>	<ol style="list-style-type: none"> 1. The infill in areas zoned residential or mixed use must respect the heritage character of the area as a whole as well as the more immediate environment. 2. Open space should generally be maintained on the rear portion of lots, with access using carriageways or side lanes. In the case of multiple-unit dwellings, entrances could be both from the sidewalk and from courtyards. The front yard setback should be the same as for adjacent heritage properties. 3. Small lot development should encourage, rather than land assembly. The density can be to the maximum allowed under height and lot coverage zoning. 4. The building form should respect the massing of adjacent heritage properties. For high-density, low-rise development, the side gable and flat roof forms have traditionally been used and continue to be the most viable options. For less dense single-family development, the front gable form could be 	<p>The proposed infill respects the character of the area as a whole. The proposal maintains the front yard set-back. The proposed mid-block connection could be considered a modern interpretation of the side lane. The proposal requires a Zoning By-law Amendment but respects the cultural heritage value of the existing building and HCD. The proposed high-rise will have a flat roof. The design of the new addition is contemporary in its proportions step backs and materiality. This development will not disrupt any sense of continuity and will in fact ensure streetscape continuity.</p>

	<p>used. Materials and detailing should reflect contemporary taste and availability, controlled only by the requirement to respect and reinforce the character of what exists. Infill must not disrupt any further the already fragile sense of continuity in many parts of the market district.</p> <p>5. Mixed use developments are historically appropriate throughout the area and could be considered on a case by case basis.</p>	
--	---	--