

2026-01-28



P.O. Box 13593, Kanata, ON K2K 1X6
Telephone: (613) 850-2475
URBAN FORESTRY & FOREST MANAGEMENT

City of Ottawa | Ville d'Ottawa
Comité de dérogation
January 24, 2026

Ben Morris
60 Pinehurst Avenue
Ottawa, ON
K1Y 1K4

RE: TREE INFORMATION REPORT (FULL) FOR 60 PINEHURST AVENUE, OTTAWA

This Tree Information Report (TIR) was prepared by Integrated Forestry Services Inc. (IFS) in support of a minor variance for 60 Pinehurst Avenue. The need for this report is related to trees protected under the City of Ottawa's Tree Protection By-law (By-law No. 2020-340). The work proposed for this address includes demolishing an existing garage and construction of a new larger, slab-on-grade garage (see plan on page 3 of this report).

Throughout the City of Ottawa, a TIR is required for infill developments and/or demolitions when a 'distinctive' tree is present (*i.e.* 30 cm in diameter at breast height (DBH) or greater). This includes distinctive trees on adjacent properties which have critical root zones (CRZ) extending onto a property slated for development or demolition. A "tree" is defined in the By-law as any species of woody perennial plant, including its root system, which has reached or can reach a minimum height of at least 450 cm at physiological maturity. The CRZ is calculated as DBH x 10 cm.

The approval of this TIR by the city and the issuing of a permit authorizes the removal of approved trees. Although this report may be used to support the application for a tree removal permit, it does not by itself constitute permission to remove trees or begin site clearing activities. No such work should occur before a tree removal permit is issued authorizing the injury or destruction of a tree in accordance with the By-law. Importantly, prior written permission from adjacent property owners is required for the removal of shared or neighbouring trees if they will be lost or terminally damaged by construction activities.

The inventory in this report details the assessment of four trees – two fully on the subject property and two on adjacent private property. No trees were found on adjacent City of Ottawa property. Field work for this report was completed in January 2026.

TREE SPECIES, CONDITION, SIZE AND STATUS

Table 1 on page 2 details the four trees. Each tree is referenced by the numbers plotted on the tree information plan included on page 3 of this report. Pictures 1 to 4 on pages 8 through 11 show the four trees.

Table 1. Tree information for 60 Pinehurst Avenue

Tree No.	Tree species /Tolerance to Construction ¹	Ownership ²	DBH ³ (cm)	CRZ ⁴ (m)	Distance to excavation (m) ⁵	Tree Condition; Age Class; Condition Notes; Species Origin and Status (to be removed or preserved and protected)	Reason for removal	Forester's Opinion re. Removal
1	Oakleaf mountain-ash (<i>Hedlundia hybrida</i>) / Unknown	Private	38.5	3.9	>10	Good; mature; central stem with competing leaders at 4.5m; upper crown moderately pruned from Hydro lines; introduced cultivar; to be preserved and protected	Not applicable – to be preserved	N.A.
2	White cedar (<i>Thuja occidentalis</i>) / Good	Neighbour	+/-40 (at 1m)	+/-4	>6	Fair; mature; multi-stemmed at 1.4m – likely topped in past; good crown density, annual increment and needle colour; crown asymmetric towards west to due past pruning from house; native species; to be preserved and protected	Not applicable – to be preserved	N.A.
3	White cedar (<i>Thuja occidentalis</i>) / Good	Neighbour	+/-35 (at 1m)	+/-3.5	<1	Fair; mature; tri-stemmed at 1.5-1.75m; crown raised to 4m; good crown density, annual increment and needle colour; broad, generally symmetric crown; native species; to be removed (see signed declaration on page 4)	Will not survive root loss	Tree be removed
4	Manitoba maple (<i>Acer negundo</i>) / Good	Private	32.2	3.2	2.5	Fair; maturing; tri-stemmed at 1.5m – co-dominant stems with suppressed lateral on east; stems moderately divergent; growing against and damaging wooden fence; naturalized species; to be preserved and protected	Not applicable – to be preserved	N.A.

¹As taken from Managing Trees during Construction; 2nd Ed., Fite and Smiley; ² Tree locations taken from site plan prepared by Paul Telfer; ³ Diameter at breast height, or 1.3m from grade (unless otherwise indicated); ⁴ Critical root zone (CRZ) is considered as being 10 centimetres from the trunk of a tree for every centimetre of DBH. The CRZ is calculated as DBH x 10 cm; ⁵Approximate distances only.

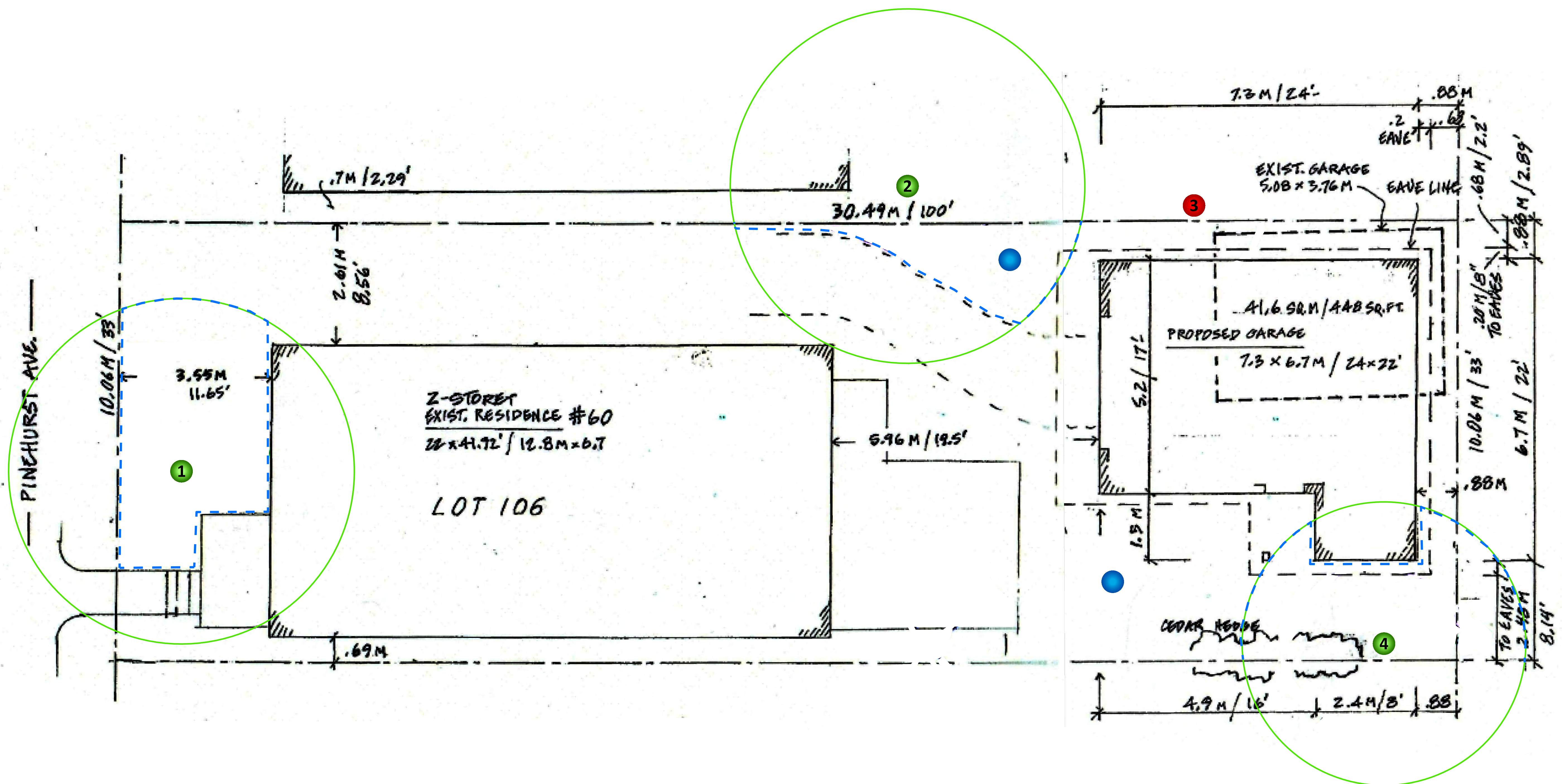

GENERAL NOTES

PLANS COMPLETED BY P. TELFER (08/01/26)

LEGEND

- TREE TO REMAIN
- CRITICAL ROOT ZONE
- - - PROTECTIVE FENCING
- TREE TO BE REMOVED
- PROPOSED NEW MEDIUM-SIZED DECIDUOUS TREE

REPLACEMENT TREE OPTIONS

Medium-sized Deciduous Trees
Kentucky coffee tree (<i>Gymnocladus dioica</i>)
Hackberry (<i>Celtis occidentalis</i>)
Red mulberry (<i>Morus rubra</i>)
Honey-locust (<i>Gleditsia triacanthos</i>)
Ginkgo (<i>Ginkgo biloba</i>)
Ohio buckeye (<i>Aesculus glabra</i>)
Pin cherry (<i>Prunus pensylvanica</i>)

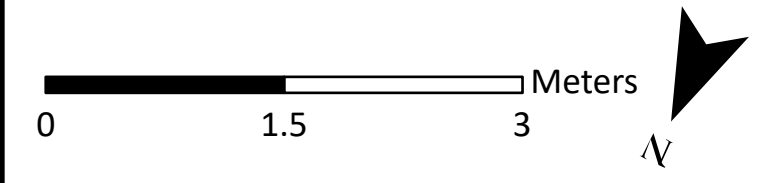

DRAWING: Tree Information Plan

PROJECT: 60 PINEHURST AVENUE
CITY OF OTTAWA



Andrew K. Boyd, R.P.F.

SCALE: 1:48	60PI
DATE: 2026-01-23	
DRAWN BY: SS	
SHEET NO: 1	



Declaration of Boundary Tree Co-owner

Declaration

I David Tipple, the property owner (s) / authorized
Print name
 representative(s) of the property owner(s) at 56 Pinehurst Avenue hereby acknowledge
Address
 that an Application for Tree Permit is being submitted to the City of Ottawa pursuant to the Tree Protection By-law No. 2020-340 by the owner(s) of 60 Pinehursts Ave (the "Applicant").
Address

I declare that I am the co-owner of the Cedar tree of
Tree Species
 size 35 cm DBH (the "Boundary Tree"). I have read and understand the required procedures and provisions under the
Diameter at breast height
 City of Ottawa's Tree Protection By-law and I consent to the intentions respecting the proposed work for which this Application for Tree Removal Permit is being made and that the statements made in this application are, to the best of my knowledge, true and complete.

- I certify that I am the legal owner(s) / authorized representative(s) of the legal owner(s) of the property where the Boundary Tree listed above is located.
- I am the co-owner of the Boundary Tree that is the subject of the application. I am aware of the content of this application and I have read and agreed to the terms of this application.
- Personal information on this form is collected under the authority of section 135 of the Municipal Act, 2001, S.O. 2001, c25 and will be used for the administration and enforcement of Tree Protection By-law 2020-340, as amended. Questions about this collection should be directed to 311.
- The City is subject to the Municipal Freedom of Information and Protection of Privacy Act, R.S.O. 1990, c.M.56, as amended ("MFIPPA") with respect to, and protection of, information under its custody and control. Accordingly, all documents provided to the City by the Applicant pursuant to this application, including this Declaration, may be available to the public unless the Party submitting the information requests that it be treated as confidential. All information is subject to MFIPPA and may be subject to release under MFIPPA, notwithstanding the applicant's request to keep the information confidential.
- I understand and acknowledge that a permit may be issued in accordance with City of Ottawa Tree Protection By-law No. 2020-340, as amended, to allow for the removal of the Boundary Tree listed above. I further understand and agree that the removal of a tree under any permit issued pursuant to this application is done at the owner's risk, and that the City of Ottawa assumes no responsibility for the removal and/or any residual effects of the removal.**

Signed on 22 Jan 2020
 Signature of Boundary Tree Co-owner [Signature]
 Address: 56 Pinehurst Avenue

SELF-DECLARATION STATEMENT (TO BE SIGNED BY PROPERTY OWNER OR REPRESENTATIVE):

Ben Morris (ben.morris@shaw.ca)

By signing the application, you are acknowledging and understanding that a city forestry inspector or municipal law enforcement officer may enter the property at a reasonable time for the purpose of carrying out an inspection. You also acknowledge and understand that through failure to abide by the recommendations of the approved Tree Information Report, damaging or destructing trees identified for protection, you alone will be responsible to bear fully the cost of compensation, removal, and replacement.

PROVINCIAL REGULATIONS

Certain provincial regulations are applicable to trees on private property. In particular, the Endangered Species Act – ESA (2007) mandates that tree species on the Species at Risk in Ontario (SARO) list be identified. Butternut (*Juglans cinerea*) and black ash (*Fraxinus nigra*) are present in Eastern Ontario and are listed as threatened on the SARO. Because of this they are both protected from harm. No trees of these two species were found on or near the subject property.

TREE PROTECTION MEASURES

Protection measures intended to mitigate damage during construction will be applied to the trees to be preserved. The following measures are the minimum required by the City of Ottawa to ensure tree survival during and following construction:

1. Erect a fence as close as possible to the critical root zone (CRZ) of trees (City of Ottawa tree protection barrier detail included on page 7).
2. Do not place any material or equipment within the CRZ of the tree.
3. Do not attach any signs, notices or posters to any tree.
4. Do not raise or lower the existing grade within the CRZ without approval.
5. Tunnel or bore when digging within the CRZ of a tree.
6. Do not damage the root system, trunk or branches of any tree.
7. Ensure that exhaust fumes from all equipment are NOT directed towards any tree's crown.

TREE PRESERVATION MEASURES

As excavation occurs within the CRZ of tree #4, the following measures will be taken under the guidance and supervision of an arborist:

1. Hydro excavation along the edge of excavation in proximity to the tree to carefully expose roots. Exposed roots will then be cleanly cut and sealed before being reburied (see City of Ottawa root pruning specifications on page 8). Excavation can then resume

using traditional mechanical means. Sealing the cleanly cut root ends with a beeswax product will help prevent the loss of moisture and facilitate healing.

2. If the excavation is to be left open for any length of time a covering of at least three layers of moistened burlap is to be draped over the exposed face of excavation closet to the tree. A final covering of clear plastic will help retain moisture within the burlap. The use of burlap and plastic coverings will help reduce the loss of moisture from the soil surrounding the remaining roots.

REPLACEMENT TREE PLANTING OR COMPENSATION

The following ratios are used in terms of replacement tree planting: 2:1 for each removed distinctive tree measuring 30-49 cm in diameter and 3:1 for each distinctive tree measuring 50 cm or greater in diameter. Replacement trees must be at least 50mm in caliper if deciduous and 2m in height if coniferous. As noted on the plan on page 3, suggested locations of two medium-sized deciduous trees are proposed in compensation for the loss of tree # 3.

This report is subject to the attached Limitations of Tree Assessments and Liability to which the reader's attention is directed.

Please do not hesitate to contact me with any questions concerning this report.

Yours,



Andrew K. Boyd, B.Sc.F, R.P.F. (#1828)
Certified Arborist #ON-0496A
Consulting Urban Forester

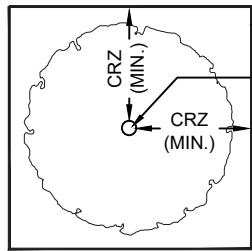

TREE PROTECTION FENCING
TREE TRUNK

PLAN VIEW

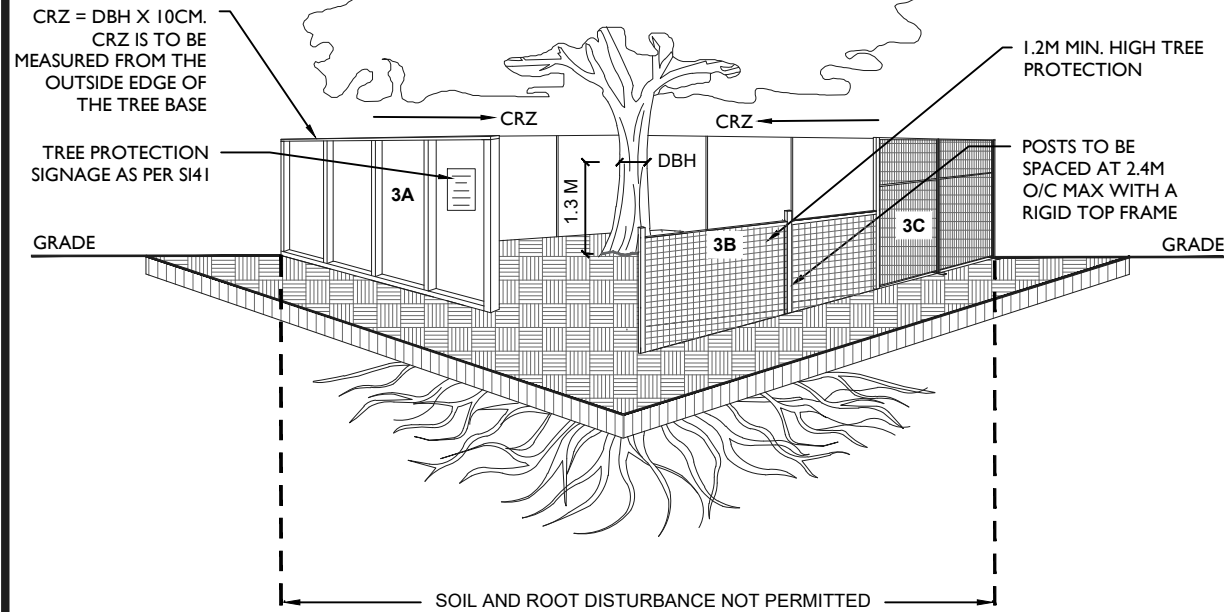

TREE PROTECTION REQUIREMENTS:

1. TREE PROTECTION FENCING MUST BE INSTALLED PER THE TREE CONSERVATION REPORT (TCR) OR THE TREE INFORMATION REPORT (TIR), WHICH EVER APPLIES, AND MUST BE DETERMINED BY AN ARBORIST AND APPROVED BY CITY FORESTRY STAFF PRIOR TO THE COMMENCEMENT OF THE WORK AND REMAIN IN PLACE UNTIL THE WORK IS COMPLETE.
 2. FOR WORK WITHIN THE TREE PROTECTION ZONE (TPZ):
 - DO NOT PLACE OR STORE ANY MATERIAL, FILL OR EQUIPMENT (INCLUDING OUTHOUSES)
 - DO NOT ATTACH ANY SIGNS, NOTICES OR POSTERS TO ANY TREE.
 - DO NOT RAISE OR LOWER THE EXISTING GRADE (SCRAPING OF THE TOP LAYER OF SOIL FOR FINAL GRADING MUST BE AVOIDED WITHIN THE CRZ, THIS INCLUDES FINAL LANDSCAPE/ REINSTATEMENT GRADING).
 - ENSURE THAT EXHAUST FUMES FROM ALL EQUIPMENT ARE DIRECTED AWAY FROM THE TREE CANOPY
 - DO NOT EXTEND/REINSTATE HARD SURFACE WITHIN THE CRZ
 - DO NOT DISPOSE OF WASTE OR VOLATILE MATERIALS, SUCH AS MINERAL SPIRITS, OIL OR PAINT THINNER
 - DO NOT OPERATE, PARK, REPAIR, OR REFUEL VEHICLES OR EQUIPMENT.
 - DO NOT DAMAGE THE ROOT SYSTEM, TRUNK OR BRANCHES OF ANY TREE
 - EXCAVATION SHALL BE CARRIED OUT BY TUNNELING, BORING OR HYDRO VAC
 3. TREE PROTECTION FENCING MUST BE AT LEAST 1.2M IN HEIGHT AND BE CONSTRUCTED OF RIGID OR FRAMED MATERIALS SUCH AS:
 - A. PLYWOOD HOARDING
 - B. SNOW FENCE
 - C. MODULAR STEEL PANELS
- INSTALLATION OF ALL FENCING TYPES, A, B OR C, MUST MINIMIZE DAMAGE TO EXISTING ROOTS.
4. ANY DEVIATION TO THE APPROVED TREE PROTECTION FENCING LOCATION MUST BE SUPERVISED BY AN ARBORIST AND APPROVED BY CITY FORESTRY STAFF. MODIFICATIONS MAY INCLUDE THE INSTALLATION OF PLYWOOD, WOOD CHIPS, OR STEEL PLATING OVER THE ROOTS, OR PERFORMING PROPER ROOT PRUNING AND CARE WHERE ROOTS ARE ENCOUNTERED.
 5. IF TREES ARE BEING AFFECTED BY CONSTRUCTION, A WATER AND FERTILIZING PROGRAM MAY BE REQUIRED.
 6. THE CITY OF OTTAWA'S TREE PROTECTION BY-LAW (NO. 2020-340) AND STANDARD F-8011 APPLY



Tree Protection

SCALE: NTS

DATE: JANUARY 2026

DRAWING NO.: F7

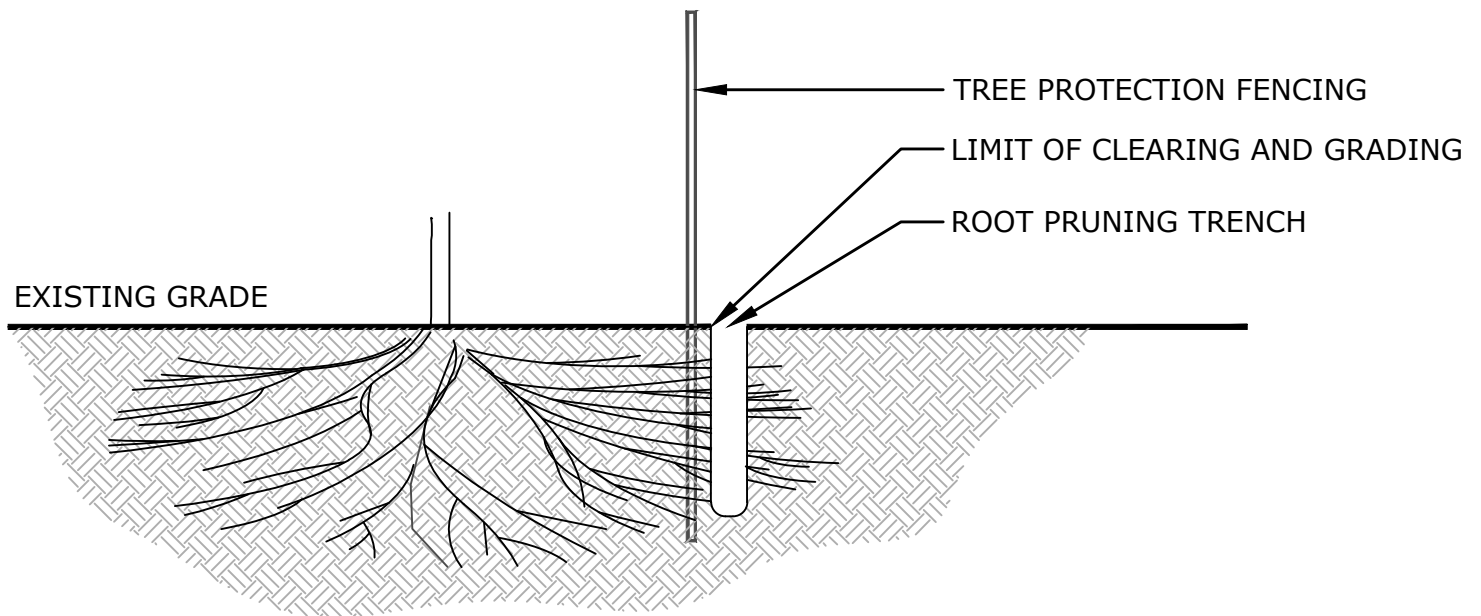

NOTES:

1. PROPER ROOT PRUNING TECHNIQUES REQUIRED WHEN TREE ROOTS ARE ENCOUNTERED DURING EXCAVATION.
2. EXCAVATION (ROOT PRUNING TRENCH) SHALL BE CARRIED OUT BY TUNNELING, BORING OR HYDRO VAC.
3. ROOTS ARE TO BE CLEANLY CUT AND THE AREA AROUND THE ROOTS SHALL BE BACKFILLED WITH SUITABLE MATERIAL, AS DETAILED IN THE CONTRACT DRAWINGS.
4. TREES SHALL BE PRUNED TO RESTORE TREE APPEARANCE AND/OR RESTORE THE BALANCE BETWEEN TOP GROWTH AND ROOTS.
5. LEADERS SHALL NOT BE PRUNED.



Picture 1. Tree #1 at 60 Pinehurst Avenue - privately owned oakleaf mountain ash to be preserved



Picture 2. Tree #2 at 60 Pinehurst Avenue – neighbouring white cedar to be preserved



Picture 3. Tree #3 at 60 Pinehurst – neighbouring white cedar to be removed



Picture 4. Tree #4 at 60 Pinehurst Avenue – private Manitoba maple to be preserved

LIMITATIONS OF TREE ASSESSMENTS & LIABILITY

GENERAL

It is the policy of Integrated Forestry Services Inc. (IFS Inc.) to attach the following clause regarding limitations. We do this to ensure that our clients are clearly aware of what is technically and professionally realistic in assessing trees for retention.

This report was prepared by IFS Inc. at the request of the client. The information, interpretation and analysis expressed in this report are for the sole benefit and exclusive use of the client. Possession of this report or a copy thereof does not imply right of publication or use for any purpose by any other than the client to whom it is addressed. Unless otherwise required by law, neither all or any part of the contents of this report, nor copy thereof, shall be conveyed by anyone, including the client, to the public through public relations, news or other media, without the prior expressly written consent of the author, and especially as to value conclusions, identity of the author, or any reference to any professional society or institute or to any initialed designation conferred upon the author as stated in his qualifications.

This report and any values expressed herein represent the opinion of the author; his fee is in no way contingent upon the reporting of a specified value, a stipulated result, nor upon any finding to be reported.

Details obtained from photographs, sketches, *etc.*, are intended as visual aids and are not to scale. They should not be construed as engineering reports or surveys. Although every effort has been made to ensure that this assessment is reasonably accurate, the tree(s) should be reassessed at least annually. The assessment presented in this report is valid at the time of the inspection only. The loss or alteration of any part of this report invalidates the entire report.

LIMITATIONS

The information contained in this report covers only the tree(s) in question and no others. It reflects the condition of the assessed tree(s) at the time of inspection and was limited to a visual examination of the accessible portions only. Integrated Forestry Services Inc. has prepared this report in a manner consistent with that level of care and skill ordinarily exercised by members of the forestry and arboricultural professions, subject to the time limits and physical constraints applicable to this report. The assessment of the tree(s) presented in this report has been made using accepted arboricultural techniques. These include a visual examination of the above-ground portions of each tree for structural defects, scars, cracks, cavities, external indications of decay such as fungal fruiting bodies, evidence of insect infestations, discoloured foliage, the condition of any visible root structures, the degree and direction of lean (if any), the general condition of the tree(s) and the surrounding site, and the proximity of people and property. Except where specifically noted in the report, the tree(s) examined were not dissected, cored, probed or climbed to gain further evidence of their structural condition. Also, unless otherwise noted, no detailed root collar examinations involving excavation were undertaken.

While reasonable efforts have been made to ensure that the tree(s) proposed for retention are healthy, no warranty or guarantee, expressed or implied, are offered that these trees, or any parts of them, will remain standing. This includes other trees on or off the property not examined as part of this assignment. It is both professionally and practically impossible to predict with

absolute certainty the behaviour of any single tree or groups of trees or their component parts in all circumstances, especially when within construction zones. Inevitably, a standing tree will always pose some risk. Most trees have the potential for failure in the event of root loss due to excavation and other construction-related impacts. This risk can only be eliminated through full tree removal.

Notwithstanding the recommendations and conclusions made in this report, it must be realized that trees are living organisms, and their health and vigour constantly change over time. They are not immune to changes in site conditions, or seasonal variations in the weather. It is a condition of this report that IFS Inc. be notified of any changes in tree condition and be provided an opportunity to review or revise the recommendations within this report. Recognition of changes to a tree's condition requires expertise and extensive experience. It is recommended that *IFS Inc.* be employed to re-inspect the tree(s) with sufficient frequency to detect if conditions have changed significantly.

ASSUMPTIONS

Statements made to IFS Inc. regarding the condition, history and location of the tree(s) are assumed to be correct. Unless indicated otherwise, all trees under investigation in this report are assumed to be on the client's property. A recent survey prepared by a Licensed Ontario Land Surveyor showing all relevant trees, both on and adjacent to the subject property, will be provided prior to the start of field work. The final version of the grading plan for the project will be provided prior to completion of the report. Any further changes to this plan invalidate the report on which it is based. Integrated Forestry Services Inc. must be provided with the opportunity to revise the report in relation to any significant changes to the grading plan. The procurement of said survey and grading plan, and the costs associated with them both, are the responsibility of the client, not IFS Inc.

LIABILITY

Without limiting the foregoing, no liability is assumed by IFS Inc. for:

- 1) Any legal description provided with respect to the property.
- 2) Issues of title and/or ownership with respect to the property.
- 3) The accuracy of the property line locations or boundaries with respect to the property.
- 4) The accuracy of any other information provided by the client or third parties.
- 5) Any consequential loss, injury or damages suffered by the client or any third parties, including but not limited to replacement costs, loss of use, earnings and business interruption; and,
- 6) The unauthorized distribution of the report.

Further, under no circumstances may any claims be initiated or commenced by the client against IFS Inc. or any of its directors, officers, employees, contractors, agents or assessors, in contract or in tort, more than 12 months after the date of this report.

ONGOING SERVICES

Integrated Forestry Services Inc. accepts no responsibility for the implementation of any or all parts of the report, unless specifically requested to supervise the implementation or examine the results of activities recommended herein. If further examination or supervision is requested, that request shall be made in writing and the details, including fees, agreed to in advance.